

HSM Compact

Your entry into automated sanding



The HSM Compact is the universal surface sanding machine for **craft businesses**. It is capable of handling applications ranging from **calibration, intermediate veneer and lacquer sanding, structuring and cleaning panels**, solid wood or veneered workpieces. Thanks to its space-saving dimensions, the HSM Compact is the optimum solution for diverse requirements. With a footprint of only 4.5 square meters, the HSM Compact is a multifunctional sanding center and ideal for producing a wide variety of surface qualities. Heesemann's smallest machine is equipped with the patented **CSD magnetic pressure beam** as a standard feature and moves you from manual sanding to automation.



Normal production volumes



Working width 1,350 mm



Sanding from above

HSM COMPACT

Up to **2** heads in a single machine frame.

A Working width

1,350 mm.

6 head combinations.

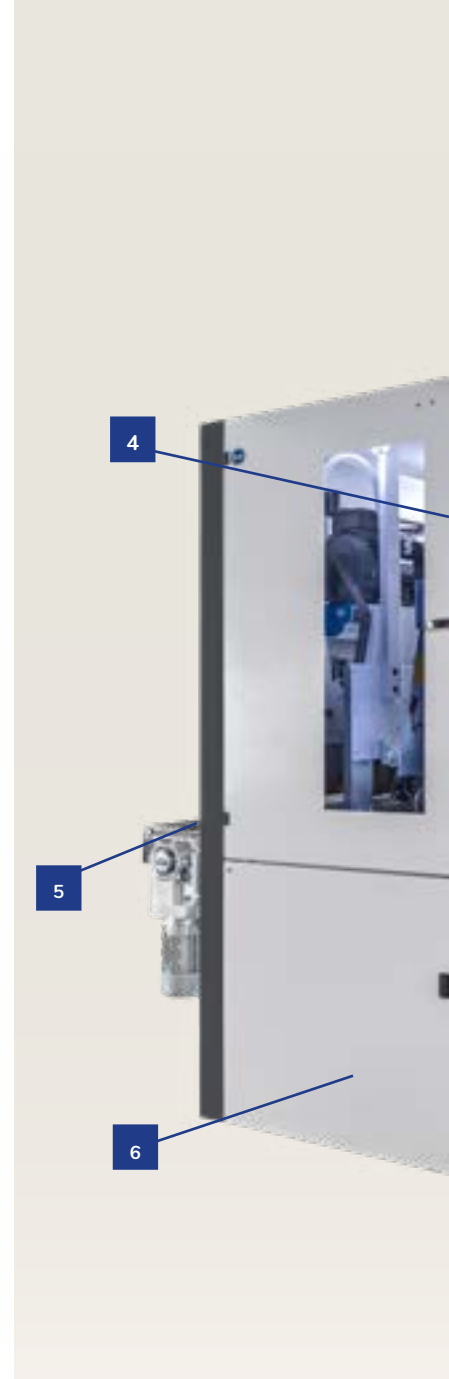

Technical data

This series covers a wide range of applications. The HSM Compact with 1 or 2 heads and 1,350 mm working width can be configured for a diverse range of applications.

HSM Compact

HSM C
2

| Configuration | Number of heads | Working width mm/inches | Abrasive belt width mm/inches | Abrasive belt length mm/inches | Workpiece thickness min. – max. mm/inches |
|----------------|-----------------|-------------------------|-------------------------------|--------------------------------|---|
| HSM .1 Compact | 1 | 1,350/53" | 1,380/54" | 2,150/85" | 3-200 /1/8" -8" |
| HSM .2 Compact | 2 | 1,350/53" | 1,380/54" | 2,150/85" | 3-200 /1/8" -8" |









- 1** Safe, secure workpiece transport ensured by high-quality, long-lasting rubberized rollers.
- 2** Integrated switch cabinet
- 3** 15.6" touchscreen operator terminal.
- 4** Doors on the belt changing side with window insert. This enables operators to view the process
- 5** The constant working height enables the use of various infeed and outfeed extensions.
- 6** The machine base houses the drive motors, vacuum ventilator and the height adjustment, protecting the components against dust and requiring no additional space.

| Compressed air consumption bar / max l / min (without options) | Dust extraction approx. m ³ /h (without options) | Length / Width / Height mm | Total connected load kW (without options) | Weight approx. kg |
|--|---|-----------------------------|---|-------------------|
| 6/20 | 1,830 | 2,342/1,911/ 1,997-2,194 | 18 | 3,500 |
| 6/40 6/60 | 3,660 | 2,342/1,911/ 1,997-2,194 | 33 | 4,000 |

YOUR SURFACES, YOUR WAY!

Configure your Heesemann machine to match your specific application and processing quantity with one to two heads and valuable optional extras. You benefit from machines optimized by the combined experience of our application engineers and customers. These models ensure the right finish and create the foundation for perfect results.

| HSM Compact Features and variants | | | | | | |
|-----------------------------------|---|-------------|------------|----------------|-----------------|-------------|
| | Head | Calibration | Solid wood | Veneer sanding | Lacquer sanding | Structuring |
| HSM .1 | C (Lk)  | ● ○ ○ | ● ○ ○ | ● ○ ○ | ● ○ ○ | optional |
| | X (Ldk)  | ● ○ ○ | ● ○ ○ | ● ● ○ | ● ● ○ | optional |
| HSM .2 | RC (LwLk)  | ● ● ● | ● ○ ○ | ● ○ ○ | ● ○ ○ | optional |
| | RH (LwLd)  | ● ● ● | ● ○ ○ | ● ● ○ | ● ● ○ | optional |
| | CH (LkLd)  | ● ○ ○ | ● ● ● | ● ● ● | ● ● ● | optional |
| HSM C | CC (LkLk)  | ● ● ● | ● ● ○ | ● ● ○ | ● ● ○ | optional |

Lk= Longitudinal unit with calibration roller

Ld= Longitudinal unit with pressure segment belt

Ldk= Longitudinal unit with pressure segment belt and calibration roller

Lw= Contact roller

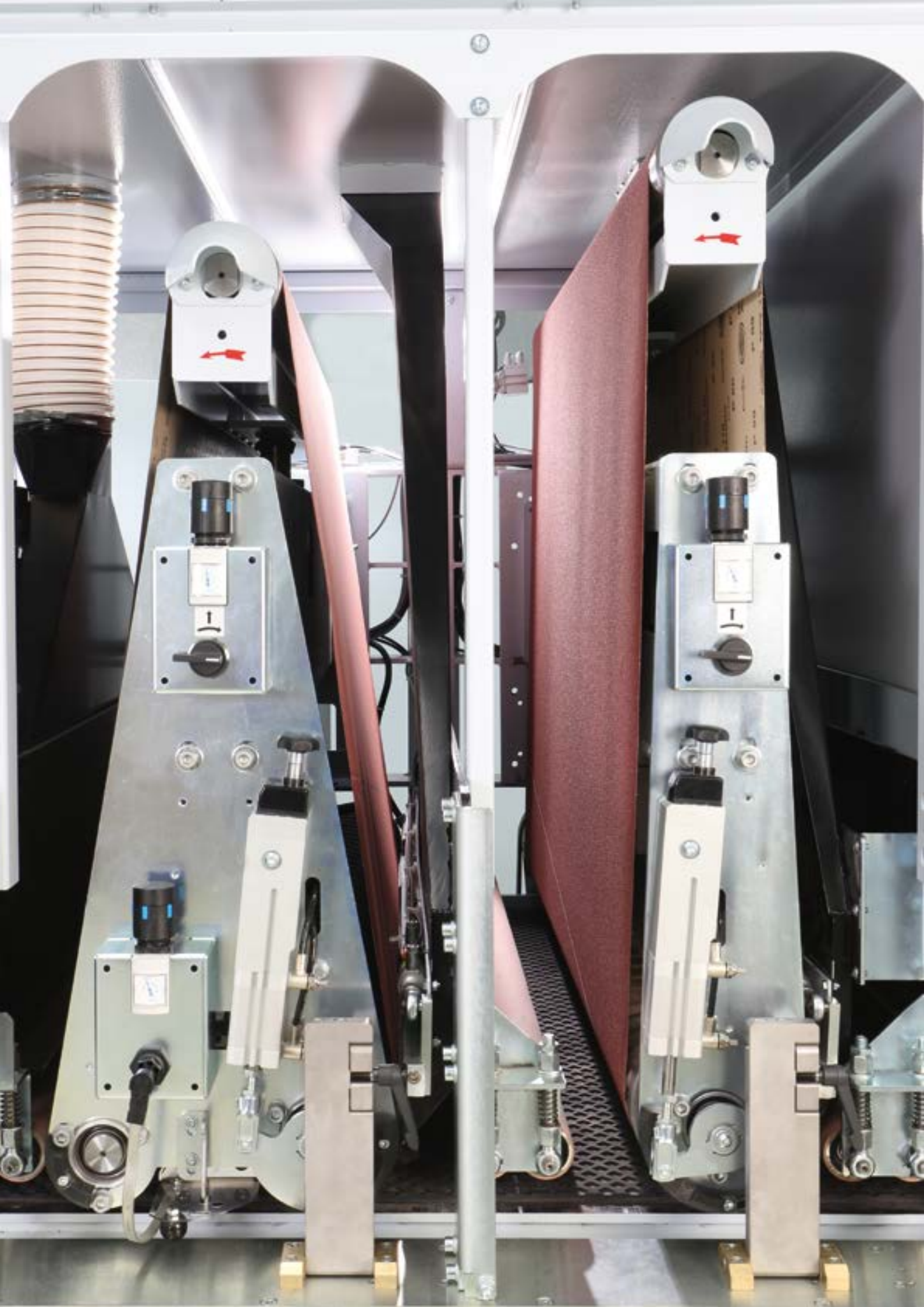

R-HEAD

DIMENSIONAL ACCURACY WITH TIGHT TOLERANCES

Do you process large quantities of solid wood and want to calibrate the full width with high removal rates? Then you are in the right place.

- The head for calibrating and roughening surfaces.
- The R-head allows precise calibration with high stock removal rates. The maintenance-free profiled contact roller is highly efficient. It prevents wash-out effects which can occur when sanding wood with large density differences, such as summer or late wood.

Applications:

- Calibrated sanding of wood and wood materials
- Roughening of surfaces to prepare for adhesive bonding.

Range of useful grains:

- Calibration: P60 - P120

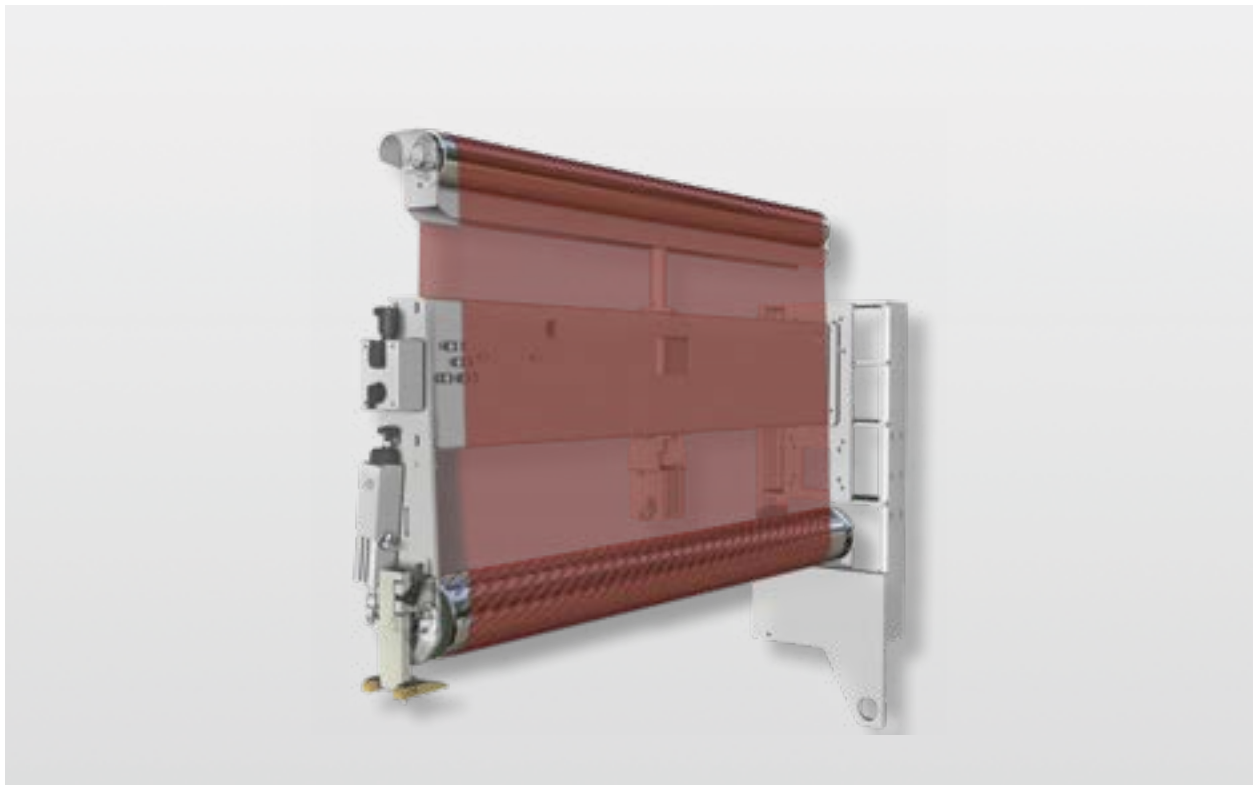

C-HEAD

THE 2 IN 1 HEAD

Do you have to calibrate and finely sand solid wood and wood-based materials? With the smallest possible machine? Then you are in the right place.

- Combined unit with profiled contact roller and CSD® magnetic pressure beam system
- The contact roller in the C-head enables precise calibration while preventing the wash-out effect.

Applications:

- Calibration and fine sanding of solid wood and wood-based materials

Range of useful grains:

- Calibration: P60 - P120
- Fine sanding: P120 - P220

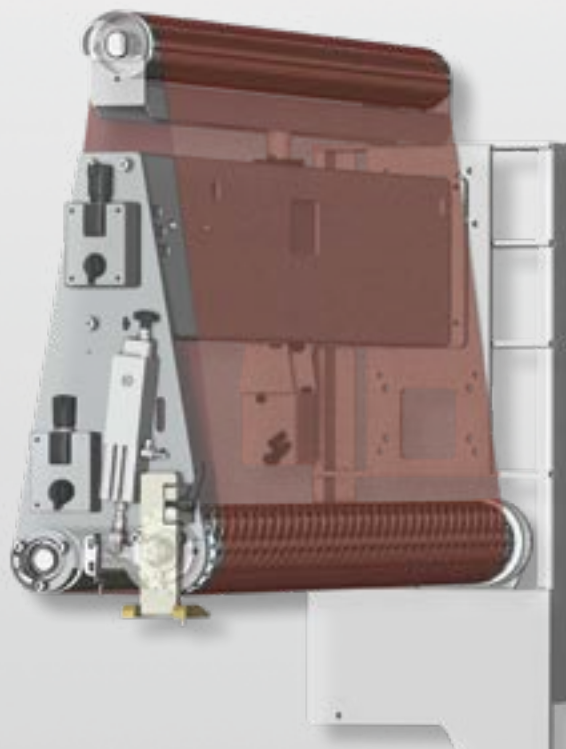

H-HEAD FINE SANDING TO PERFECTION

Do you value high-quality surfaces? Then you are in the right place.
The perfect head for veneer, paint and filler sanding.

- Using the pressure pad with CSD® system can compensate for thickness tolerances of up to 2 mm.
- Capable of adapting to diverse materials due to the steplessly variable cutting speed.
- Prevents sanding through on the surface and at the edges.
- The lamellar pressure belt produces a smooth, homogeneous surface, preventing unwanted oscillation lines.
- Lower sanding temperatures increase the service life of the sanding tool.

Applications:

- High-quality sanding finish on a variety of surfaces
- Paint and filler sanding up to very fine grains
- Solid wood pulp, especially for frame parts

Range of useful grains:

- High-gloss preparation sanding up to P1200 grit



QUICK CHANGE BRUSH UNIT

Barrel brush head | 3D finish

- Fine sanding of wood and wood-based materials as well as painted surfaces
- Refine the sanding pattern of upstream processes
- Suitable for machining three-dimensional workpiece surfaces



Structuring brush Anderlon

- Ideal for light to medium structuring of hardwood and softwood.



Structuring brush Stranded wire

- Ideal for intense structuring of hardwood and softwood



Glazing brush

- Recommended for smoothing and highlighting pores on lacquered surfaces



AS STANDARD ALL INCLUSIVE

The HSM Compact features top-quality equipment from the ground up. The key technologies to ensure lasting first-class processing quality are always included as standard.



Workpiece thickness setting

- Precise height adjustment from 3-200 mm via four height adjustment gears



Workpiece thickness measuring

- Device for automatic thickness measurement across the entire processing width
- Machine automatically configured for the required thickness



HSM C

10

15.6" touch display

- User-friendly and ergonomic operation using the large 15.6" touch display
- Fast and precise touchscreen control
- Intuitive operation via clearly understandable icons (proven Heesemann user interface)



Steplessly variable cutting speed control

- Speed control via the frequency converter
- Power transmission via poly-V-belt
- Applies to all aggregates
- Infinitely adjustable feed rate from 2.5-13 m/min

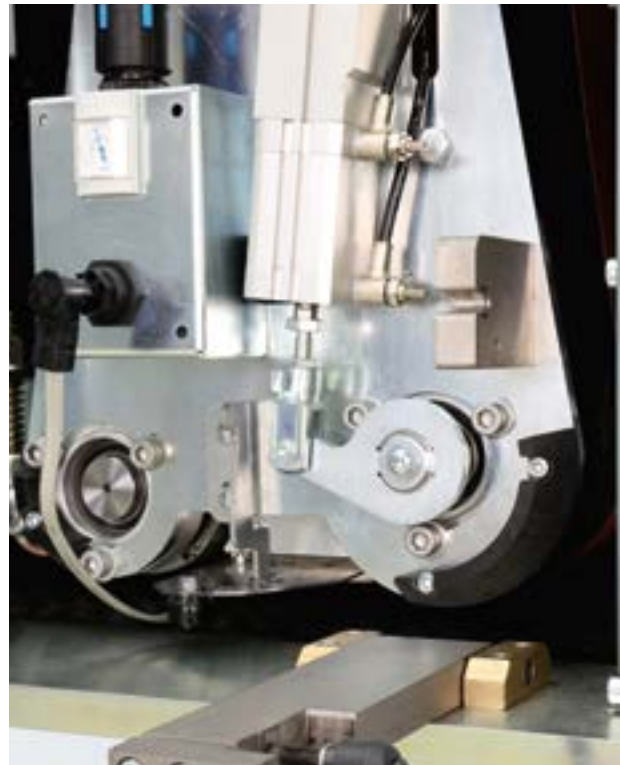

Head locking

Safe and simple quick-lock heads to rapidly change the sanding belt



Standard highlights include:

- Energy-saving vacuum thanks to infinitely variable blower
- Constant working height of 880 mm
- Infeed rollers guarantee easy workpiece handling
- Maintenance-free electronic braking system
- Prepared for retrofitting various brushing and cleaning units

Non-contact sanding belt oscillation

- The sanding belt is controlled by means of large dimensioned light scanners
- This achieves extremely smooth oscillation



Air-jet belt blower

- Integrated air-jet belt blower
- Workpiece-controlled for low compressed air consumption



Vacuum clamping system

- Safely transport small or lacquered workpieces



Profiled contact rollers made of:

- Steel
- Rubber

OPTIONAL EXTRAS THAT ARE REALLY WORTH IT!

Do you want to take things to the next level? Our optional extras offer you all the options you need to adapt your wide-belt sanding machine to your unique production needs.



Folding table

- Stable folding table – a useful addition when space is tight

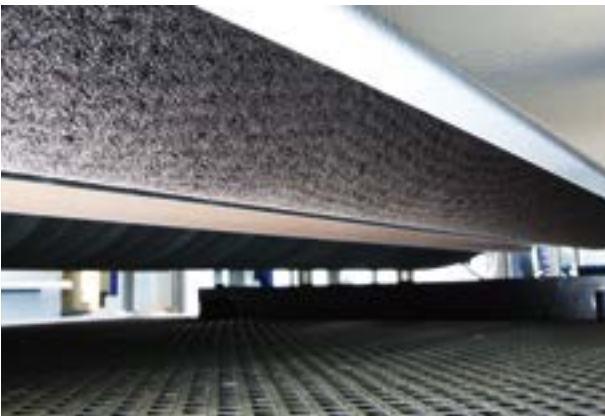

Powered finishing brush

- Gently clean the workpiece surface with horse hair trim



Workpiece cleaning rotors

- Workpiece cleaning using rotating blow-off sprayers
- Ionisation unit to neutralise electrostatic charge for improved workpiece cleaning

Also available (not shown):

- Roller table in the outlet
- Service trolley for easier changing of brush units on interchangeable frames
- Workpiece inspection light

HEESEMANN CSD® MAGNETIC PRESSURE BEAM



Adaptive sanding for uniform surfaces

Precise control of the sanding pressure is crucial to achieve consistently high grinding quality. The computer-controlled selective pressure control of the CSD® magnetic pressure beam system enables the sanding pressure of each element on the pressure beam to be steplessly adjusted in a matter of milliseconds. Fine scanning on the infeed of the machine ensures the exact calculation of the required pressure.

This elastic pressure beam is capable of compensating for tolerances in the workpiece thickness of 2 mm and more, on a single workpiece and also between workpieces.

The magnetic CSD® pressure beam system eliminates the soiling of the pressure beam elements that can otherwise occur with pneumatically operated systems. The CSD® magnetic pressure beam is installed on all Heesemann cross sanding and longitudinal sanding units as a standard feature.

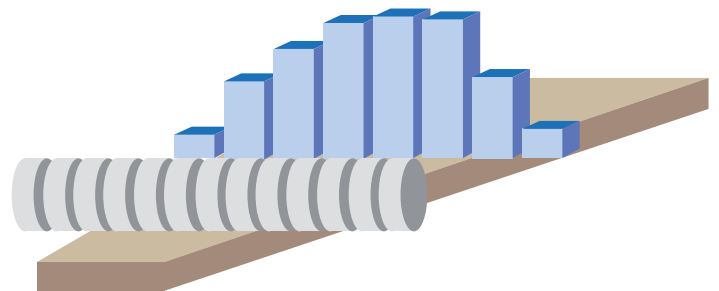

HEESEMANN ENERGY MANAGEMENT SYSTEM (EMS)



Benefits for the environment and users



With Heeseemann's EMS energy-saving system, our environment and users benefit equally: Decreasing energy consumption reduces both the burden on the environment and your costs.

When no workpieces enter the machine, the drive motors in the units reduce speed. This significantly reduces the energy consumption of the machine depending on the workload. When new workpieces are run in, all motors are quickly started up again.

HSM C

15

Karl Heesemann
Maschinenfabrik GmbH & Co. KG
Reuterstraße 15
32547 Bad Oeynhausen

verkauf@heesemann.de
www.heesemann.de



2024-05